

ND 系列高转差油田泵用三相异步电动机

ND Series High Slip Induction Motor Special For oil pump



1.5 THRU 100HP

NEMA 180 THRU 440T

HIGH SLIP

POLES : 6

Applications: Typical applications include operations where continuous or frequent duty is required. Class F insulated, 1.15 service factor, suitable for the oil pump unit.

Features: Cast iron frames, IP55 protection, high slip, steep mechanical performance, energy conservation, large margin of safety in temperature rise, low noise, small vibration, high safety and reliability in service and etc.

One power motor voltage: 230/460V OR 230/460/796V

Three power motor voltage: 460V OR 230V OR 796V

Performance Data

(One power motor)

HP	Full load r/min	Frame	Conn.	Slip %	Current at 460V			Torque			Efficiency			Power Factor		
					Idle	Full load (A)	Locked Rotor (A)	Full load (LB-FT)	Locked Rotor %	Break down %	Full load %	3/4 load %	1/2 load %	Full load %	3/4 load %	1/2 load %
1.5	1110	182T	2Y/Y	7.50	2.38	2.7	20	7.11	320	310	78.5	77.6	75.6	66.0	60.3	46.7
2	1110	184T	2Y/Y	7.50	2.59	3.6	25	9.47	300	280	78.5	79.3	78.3	66.0	64.8	51.3
3	1140	213T	2Y/Y	5.00	3.54	4.8	32	13.84	290	280	81.0	82.7	81.6	72.0	66.1	52.9
5	1135	215T	2Y/Y	5.42	5.11	7.6	46	23.16	280	260	82.5	84.3	83.6	75.0	69.0	56.2
7.5	1135	254T	2Δ/Δ	5.42	3.79	11.2	64	34.74	290	250	82.5	86.1	85.7	76.0	72.4	60.7
10	1135	256T	2Δ/Δ	5.42	5.07	14.6	81	46.32	310	255	84.0	86.7	86.2	76.1	72.2	60.5
15	1125	284T	2Δ/Δ	6.25	6.90	20.8	116	70.10	310	275	85.5	87.5	87.2	79.0	76.1	64.8
20	1125	286T	2Δ/Δ	6.25	8.51	27.7	145	93.47	310	275	85.5	87.9	87.8	79.0	77.4	66.8
25	1130	324T	2Δ/Δ	5.83	9.49	32.2	183	116.32	280	275	85.5	88.9	89.1	85.0	80.2	70.0
30	1125	326T	2Δ/Δ	6.25	10.0	38.7	218	140.21	275	275	85.5	89.2	89.6	85.0	82.4	73.5
40	1100	365T	2Δ/Δ	8.33	12.3	50.3	363	191.19	280	275	86.5	88.3	88.9	86.0	84.1	76.0
50	1120	404T	2Δ/Δ	6.67	12.2	62.2	435	234.72	275	275	87.5	89.7	90.4	86.0	88.4	82.1
60	1120	405T	2Δ/Δ	6.67	13.9	74.7	543	281.66	275	275	87.5	89.8	90.5	86.0	88.9	83.1
75	1130	444T	2Δ/Δ	5.83	25.3	92.3	725	348.96	275	300	88.5	90.7	90.8	86.0	82.5	73.0
100	1130	445T	2Δ/Δ	5.83	32.8	123.0	908	465.29	290	290	88.5	92.2	91.9	86.0	81.8	72.7

NOTE: For current at 230V or 796V, multiple above values by 2 or 0.578.

Performance Data

(Three power motor)

HP	Full load r/min	Frame	Conn.	Slip %	Current at 460V			Torque			Efficiency			Power Factor		
					Idle	Full load (A)	Locked Rotor (A)	Full load (LB-FT)	Locked Rotor %	Break down %	Full load %	3/4 load %	1/2 load %	Full load %	3/4 load %	1/2 load %
15	1125	284T	△	6.25	5.31	19.9	106	70.01	310	275	86.4	87.4	87.2	81.6	76.1	64.8
10	1140			5.00	3.84	13.5	78	46.06	320	300	87.5	87.8	86.9	79.3	72.9	60.7
7.5	1135			5.42	2.43	9.8	54	34.70	290	280	87.7	88.4	87.9	82.1	77.0	66.2
20	1125	286T	△	6.25	6.55	26.2	145	93.35	310	275	86.9	87.9	87.7	82.4	77.5	66.8
15	1135			5.42	4.87	19.6	110	69.39	310	280	87.5	88.2	87.8	82.1	77.1	66.2
10	1135			5.42	3.10	12.9	75	46.26	290	285	88.0	88.7	87.9	82.7	77.9	64.2
30	1110	364T	△	7.50	7.86	37.6	218	141.91	275	275	86.7	88.1	88.4	86.1	82.4	73.2
20	1125			6.25	6.07	25.2	145	93.35	320	300	87.9	88.7	88.3	84.6	79.5	68.8
15	1120			6.67	3.98	18.6	110	70.32	280	315	87.8	88.8	88.6	86.2	82.1	72.7
40	1100	365T	△	8.33	9.43	49.6	278	190.93	280	275	86.6	88.3	88.9	87.2	84.1	76.0
30	1110			7.50	7.21	36.9	208	141.91	290	280	87.3	88.7	87.2	87.1	83.8	75.4
20	1110			7.50	4.73	24.5	135	94.61	260	285	87.6	89.0	89.3	87.3	84.0	75.7
50	1120	404T	△	6.67	10.35	58.7	405	234.41	275	275	88.6	89.8	90.3	90.0	84.3	80.0
40	1120			6.67	7.78	46.7	300	187.52	290	315	88.8	90.0	90.4	90.4	87.9	81.2
30	1115			7.08	5.05	34.9	205	141.27	250	280	88.3	89.8	90.5	91.1	89.4	84.0
60	1120	405T	△	6.67	10.70	70.2	450	281.29	275	275	88.1	89.7	90.5	90.9	85.0	83.1
50	1115			7.08	8.20	58.3	345	235.46	250	270	88.0	89.4	90.6	91.3	90.2	84.5
40	1095			8.75	5.38	47.3	258	191.81	220	255	86.7	89.0	90.5	91.4	91.0	87.5
75	1130	444T	△	5.83	22.26	91.4	600	348.50	275	300	91.6	91.8	91.2	83.9	78.8	68.1
60	1130			5.83	17.05	72.5	458	278.80	290	310	91.7	91.9	91.3	84.5	79.7	69.3
50	1125			6.25	11.25	59.1	308	233.36	240	275	91.3	91.9	91.8	86.8	83.6	75.8
100	1130	445T	△	5.83	29.84	121.8	808	464.66	290	290	91.7	91.9	91.3	83.8	78.7	67.9
75	1130			5.83	22.29	91.1	610	348.50	310	320	91.9	92.0	91.3	83.9	78.7	67.9
60	1125			6.25	14.63	71.1	406	280.04	270	290	91.7	92.1	91.8	86.2	82.6	73.7

NOTE: For current at 230V or 796V, multiple above values by 2 or 0.578.

FOOT MOUNTING DIMENSION

inch

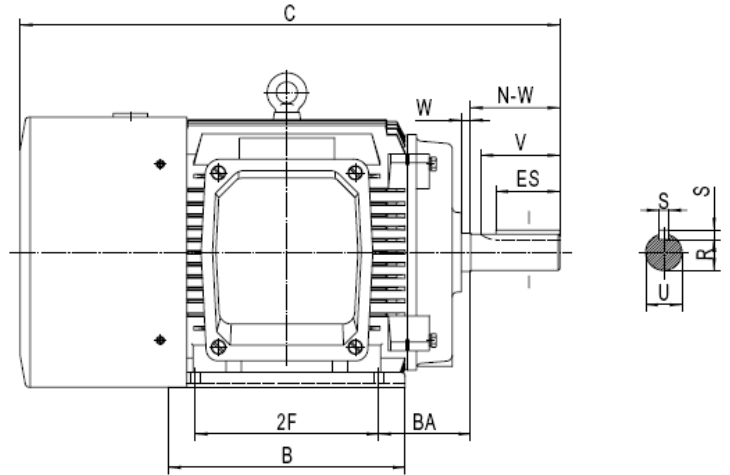
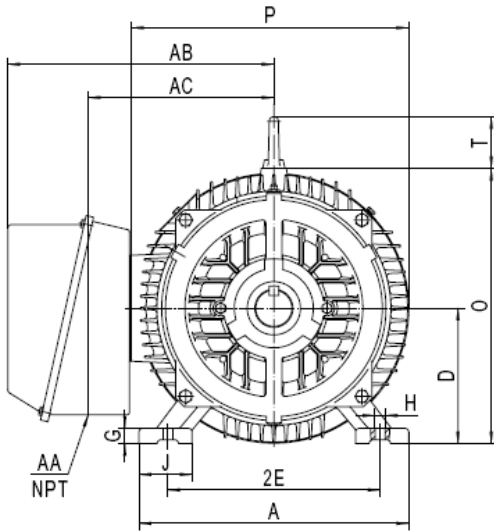

ALL DATA SUBJECT TO CHANGE WITHOUT NOTICE. USE ONLY CERTIFIED DATA FOR CONSTRUCTION PURCHASES.

Frame	MOUNTING				A	B	C	D	G	J	O	P	R	S	T	W	AB	AC	SHAFT EXTENSION			BEARINGS	
	E	F	H	BA															N-W	U	V	DRIVE END	OPPOSITE DRIVE END
182T	3.75	2.25	0.41	2.75	9.0	6.5	15.3	4.5	0.669	2.04	9.0	9.37	0.986	0.250	1.58	0.14	7.48	4.53	2.75	1 1/8	2.50	6306	6306
184T	3.75	2.75	0.41	2.75	9.0	7.5	16.0	4.5	0.669	2.04	9.0	9.37	0.986	0.250	1.58	0.14	7.48	4.53	2.75	1 1/8	2.50	6306	6306
213T	4.25	2.75	0.41	3.50	10.5	7.5	19.0	5.25	0.787	2.45	10.5	10.9	1.201	0.312	1.97	0.14	8.27	7.09	3.38	1 3/8	3.12	6208	6208
215T	4.25	3.50	0.41	3.50	10.5	9.0	22.5	5.25	0.787	2.45	10.5	10.9	1.201	0.312	1.97	0.14	8.27	7.09	3.38	1 3/8	3.12	6208	6208
254T	5.0	4.125	0.53	4.25	12.5	10.8	23.4	6.25	0.866	2.87	12.8	13.0	1.416	0.375	2.35	0.14	10.43	8.07	4	1 5/8	3.75	6309	6309
256T	5.0	5.0	0.53	4.25	12.5	12.5	25.1	6.25	0.866	2.87	12.8	13.0	1.416	0.375	2.35	0.14	10.43	8.07	4	1 5/8	3.75	6309	6309
284T	5.5	4.75	0.53	4.75	14.0	12.5	28.0	7.0	0.80	2.756	14.5	14.1	1.591	0.375	2.35	0.144	13.78	8.46	4.62	1 7/8	4.38	6310	6310
286T	5.5	5.5	0.53	4.75	14.0	14.0	29.5	7.0	0.80	2.756	14.5	14.1	1.591	0.375	2.35	0.144	13.78	8.46	4.62	1 7/8	4.38	6310	6310
324T	6.25	5.25	0.66	5.25	16.0	14.0	30.3	8.0	1.11	2.756	16.0	15.63	1.045	0.50	2.50	0.191	14.76	10.63	5.25	2 1/8	5.00	6312	6312
326T	6.25	6.0	0.66	5.25	16.0	15.5	31.8	8.0	1.11	2.756	16.0	15.63	1.845	0.50	2.50	0.191	14.76	10.63	5.25	2 1/8	5.00	6312	6312
365T	7.0	6.125	0.66	5.88	18.0	16.2	34.15	9.0	1.25	2.953	18.25	17.56	2.021	0.625	2.50	0.205	16.14	12.60	5.88	2 3/8	5.62	6314	6314
404T	8.0	6.125	0.81	6.62	20.0	16.2	37.0	10.0	1.34	3.15	20.0	19.0	2.45	0.75	2.50	0.165	18.11	12.20	7.25	2 7/8	7.00	6316	6316
405T	8.0	6.875	0.81	6.62	20.0	17.8	38.5	10.0	1.34	3.15	20.0	19.0	2.45	0.75	2.50	0.165	18.11	12.20	7.25	2 7/8	7.00	6316	6316
444T	9.0	7.25	0.81	7.5	22.0	18.5	42.75	11.0	1.38	3.35	21.75	21.6	2.88	0.875	2.91	0.35	19.49	14.76	8.5	3 3/8	8.25	NU318	6316
445T	9.0	8.25	0.81	7.5	22.0	20.5	44.75	11.0	1.38	3.35	21.75	21.6	2.88	0.875	2.91	0.35	19.49	14.76	8.5	3 3/8	8.25	NU318	6316

TEFC C-FACE MOUNTING DIMENSIONS

inch

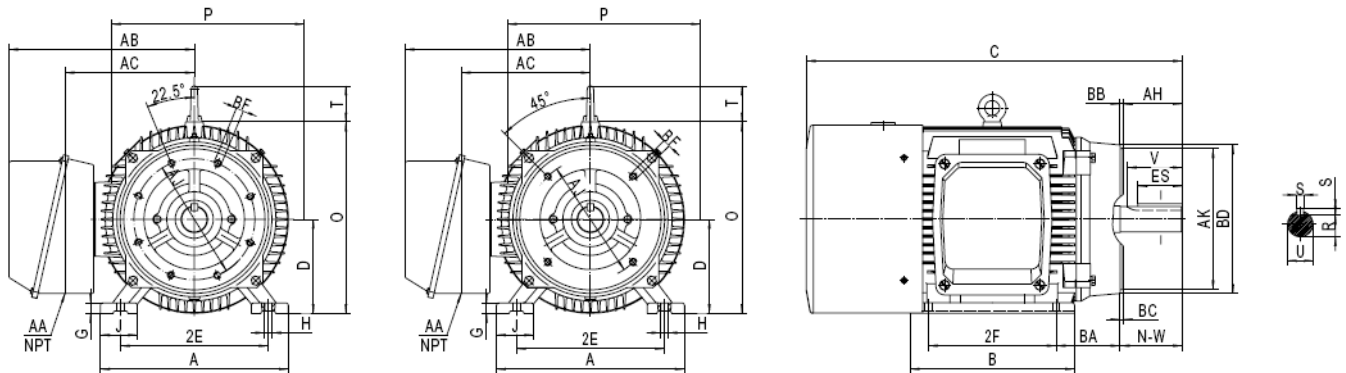

FRAME	AJ	AK	BA	MIN BB	BC	MAX BD	NUMBER OF HOLE	SCREW	DEPTH OF HOLE	U	AH	R	ES	S
182TC.184TC	7.250	8.500	3.50	0.25	0.12	9.00	4	1/2-13	0.75	1.125	2.62	0.986	1.78	0.250
213TC.215TC	7.250	8.500	3.50	0.25	0.25	9.00	4	1/2-13	0.75	1.375	3.12	1.201	2.41	0.312
254TC.256TC	7.250	8.500	4.75	0.25	0.25	10.00	4	1/2-13	0.75	1.625	3.75	1.416	2.91	0.375
284TC.286TC	9.000	10.500	4.75	0.25	0.25	11.25	4	1/2-13	0.75	1.875	4.38	1.591	3.28	0.500
324TC.326TC	11.000	12.500	5.25	0.25	0.25	14.00	4	5/8-11	0.94	2.125	5.00	1.845	3.91	0.500
365TC	11.000	12.500	5.88	0.25	0.25	14.00	8	5/8-11	0.94	2.375	5.62	2.021	4.28	0.625
404TC.405TC	11.000	12.500	6.62	0.25	0.25	15.50	8	5/8-11	0.94	2.875	7.00	2.450	5.65	0.750
444TC.445TC	14.000	16.000	7.50	0.25	0.25	18.00	8	5/8-11	0.94	3.375	8.25	2.880	6.91	0.875

NOTE:

1. Tolerance on dimension D: +0.00inch, -1/32 inch for frame 182~326; +0.00 inch -1/16 inch for frames 365~445.
2. Tolerance on shaft diameter U: +0.0000 inch, -0.0005 inch for frames 182~215; +0.000 inch, 0.001 inch for frame 254~445.
3. Tolerance on dimension R: +0.000 inch, -0.015 inch.
4. Dimension V is length of straight part shaft.
5. The conduit box can be rotated 90° increments so that conduit can be received from any direction. Conduit box can be located on either side of the motor.
6. The last letter "Z" designated suitability for belt drive application.